



Product manual KSA, KSB

STEAM GENERATOR

KSA-30
KSA-40
KSA-45
KSA-50
KSA-60
KSA-70
KSA-80

KSA-90
KSA-105
KSA-120
KSA-150
KSA-180
KSA-225
KSA-240



CONTENT

INTRODUCTION	3
CHAPTER 1 PARAMETERS	4
CHAPTER 2 INSTALLATION AND CAUTIONS	7
CHAPTER 3 FUNCTIONS AND OPERATION	16
CHAPTER 4 MAINTENANCE	18
CHAPTER 5 TROUBLESHOOTING	19
CHAPTER 6 WARRANTY AND SERVICES	20

INTRODUCTION

Thank you for choosing KSA series steam generator with well-designed structure, steady performance and convenient installation. To form the whole set of steam bathing equipment, you need a personal steam bathing room as well. The steam generator is designed to remove tiredness, relax muscles and stimulate blood circulation.

For proper installation, operation, maintenance, and the safety of customer as well, please read all instructions carefully and keep this manual for further reference.

ATTENTION: This appliance is not intended for use by person with reduced physical, sensory or mental capabilities, or lack of experience and knowledge, unless they have been given supervision or instruction concerning use of the appliance by a person responsible for their safety.

ATTENTION: Children should be supervised to ensure that they do not play with the appliance.

ATTENTION : Check steam room before restart the controller.

ATTENTION: No smoking or alcohol is allowed inside the steam room.

ATTENTION: Leave the steam room immediately when feels uncomfortable.

ATTENTION: A ventilation fan is required outside the steam room.

CHAPTER 1 PARAMETERS

1. Models, parameters and dimension

Model	Power (kW)	Heating elements (N*kW)	Voltage/Current (V/A)	Power wire (N*mm ²)	Breaker (A)	Room volume (m ³)	Dimension (L*W*H) (mm)
KSA-30	3.0	2*1.5	220-240/13.6	3*2.5	16	2 ~ 3	425*160*315
KSA-40	4.0	2*2.0	220-240/18.2	3*2.5	25	3 ~ 5	
KSA-45	4.5	3*1.5	220-240/20.5	3*2.5	25	3.5 ~ 5.5	
			380-415/6.8	5*1.5	16		
KSA-50	5.0	2*1.5+1*2.0	220-240/22.7	3*2.5	32	4 ~ 6	
			380-415/9.1	5*1.5	16		
KSA-60	6.0	3*2.0	220-240/27.3	3*4.0	40	5 ~ 7	
			380-415/9.1	5*1.5	16		
KSA-70	7.0	2*2.5+1*2.0	220-240/31.8	3*6.0	40	5.5 ~ 8	
			380-415/11.4	5*2.5	16		
KSA-80	8.0	2*2.5+1*3.0	220-240/36.4	3*6.0	60	6.5 ~ 9	
			380-415/13.6	5*2.5	16		
KSA-90	9.0	6*1.5	380-415/13.6	5*2.5	16	8 ~ 11	475*185*450
KSA-105	10.5	3*1.5+3*2.0	380-415/15.9	5*2.5	25	9 ~ 12	
KSA-120	12.0	6*2.0	380-415/18.2	5*2.5	25	11 ~ 14	
KSA-150	15.0	6*2.5	380-415/22.7	5*2.5	32	13 ~ 18	
KSA-180	18.0	9*2.0	380-415/27.3	5*4.0	40	16 ~ 22	520*205*490
KSA-225	22.5	9*2.5	380-415/34.1	5*6.0	60	19 ~ 26	
KSA-240	24.0	6*2.5+3*3.0	380-415/36.4	5*6.0	60	22 ~ 30	

Table 1

Notice:

- The rated power is measured under single phase 230V, therefore the actual operating power under single phase 220-240V, 50/60Hz, or three phases 380-415V, 50/60Hz may be different from the rated value.
- We do not recommend customer to choose the KSA-80.

Figure 1

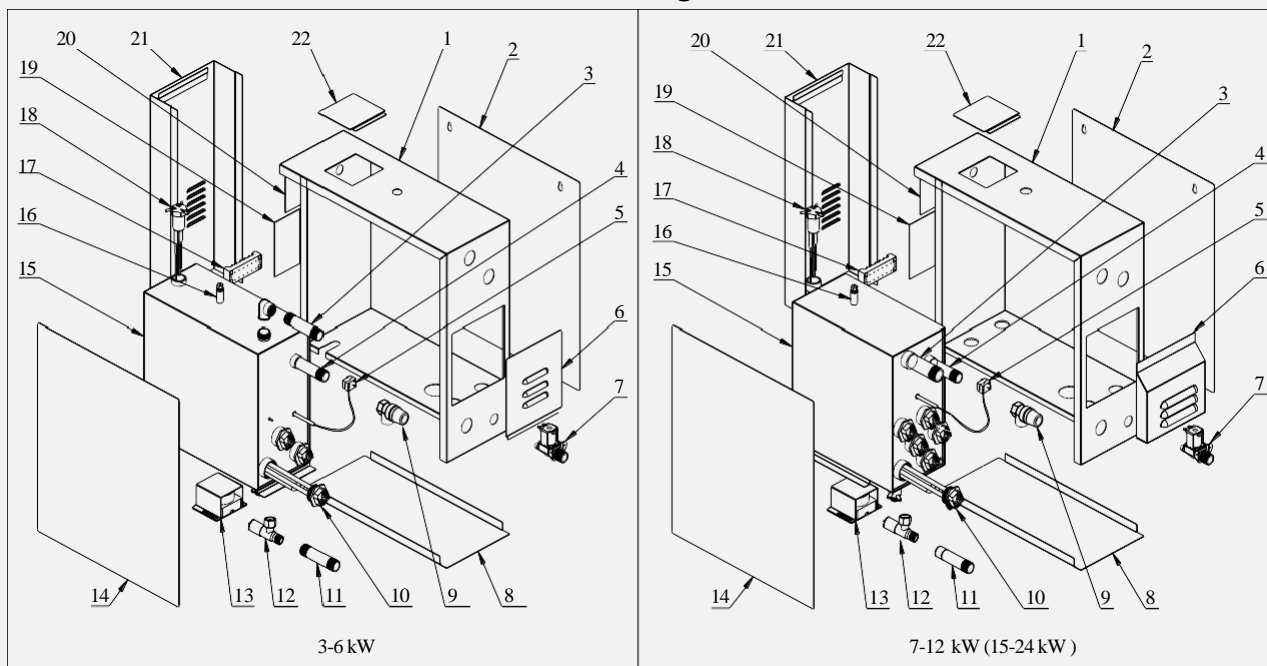

- 1.Frame
- 2.Side panel
- 3.Steam outlet (two for 15kW and above)
- 4.Pressure relief valve connection pipe
- 5.Temp-control switch
- 6.Frontal access cover
- 7.Water inlet solenoid
- 8.Bottom panel
- 9.Safety valve
- 10.Heating elements
- 11.Draining pipe
- 12.Drain valve

- 13.Drain motor
- 14. Side panel
- 15.Inner tank
- 16.Service hole
- 17.Wiring terminal
- 18.Water level sensor
- 19.Sub-board
- 20.Main-board
- 21.U-shape cover
- 22.Water level sensor access cover

Figure 2

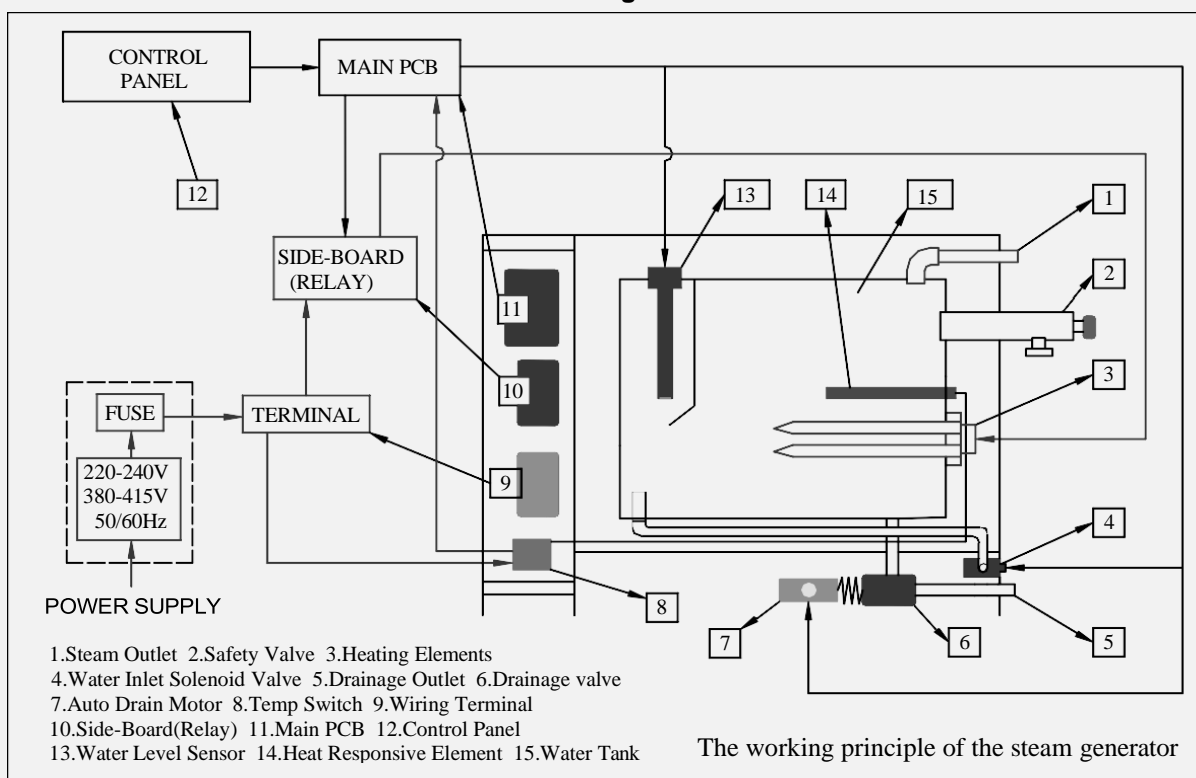

The working principle of the steam generator

1. Controller parameters and dimension

Table 2

Model	Controller model	Controlling time range (minutes)	Temperature display range	Temperature controlling range	dimension (mm)
KSA series	KS-200A	1 ~ 60 or long-term	6 ~ 60°C (43°F ~ 140°F)	35 ~ 55°C (95 ~ 131°F)	113.5*102*17

Notice: the temperature sensor should be installed separately and connected to the controller with wire. We recommend you to install the controller outside the steam room.

KS-200A controller

Figure 3

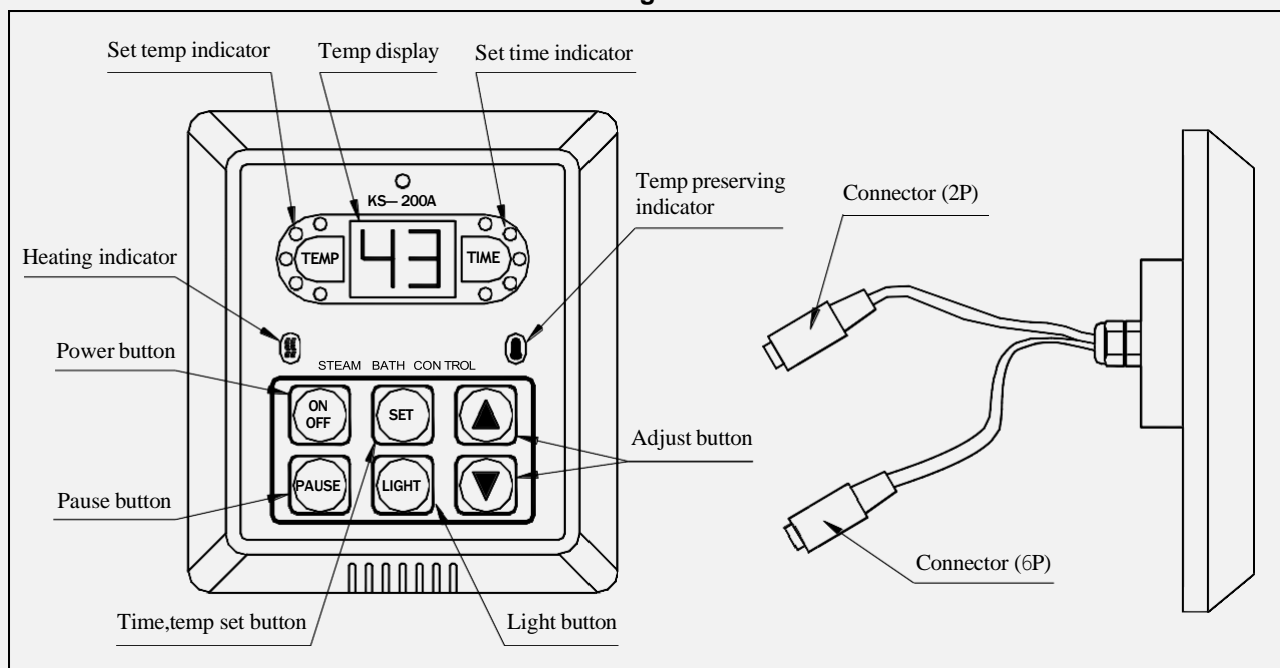

Cautions:

- If the generator is installed at a place where difficult for customer access, the water supply valve must be easy to access for emergencies.
- GFCI must be installed on the power supply, and the power supply, power wire, fuse and breaker must comply with the nameplate one the unit and table 1 in this manual.
- The solenoid valve can endure 0.06-0.55MPa (0.6-5.5kg/cm²) water pressure. To protect the solenoid valve from extremely high water pressure, please turn down the inlet slightly or install water pressure relieving valve .
- Do not install saddle-backed or needle valves on the inlet. Please dredge and clean the pipe before installation.
- No block valve should be installed in the steam pipelines. Strictly no blocked or blended pipe otherwise have negative effect on the flow of steam and condensate. The steam pipelines should be installed with a slight angle so that the condensate can flow back to the generator or the steam head.
- Steam generator should be installed indoor to avoid frozen. The generator should be installed and leveled with the arrow pointing upward at an easy-access place, otherwise do not switch on.
- The steam pipeline must be copper pipes, all other material such as plastic, acrylic should not be used since they cannot endure 150°C or higher. temperature
- All inlet and apertures should be sealed to prevent any leakage of steam and to protect the generator and customers.
- Draining water to the steam room from the water tank may cause serious scald and damage the steam room.

1. Selecting the proper steam generator:

In order to achieve comfort and relaxation, as well as energy efficiency, the selection of the correct steam generator model and size are as critical as design of the steam room itself. The power supply and circuit protector should be carefully checked to match the parameters of the generator. Please referring to the table 1 and select the suitable model for your specification.

2. Installation of steam generator

- Switch off all power supply before installation, and check whether you have the correct model for your steam room according to table 1.
- A manual resetting 110C temperature control switch is installed in the steam generator for over-heat protection. If temperature of inner tank exceeds 110C accidentally, the switch will automatically disconnect power supply to main-board. In this case, it is necessary to disconnect the power supply to steam generator, and then carefully check heating elements, relay on sub-board and water supply pipeline after steam generator completely cooling-down. The temperature switch could only be manually reset after the fault has been located and solved. The temperature control switch is as shown in figure 8.
- Do not install the generator outdoors, in wet/moist place, freezing, or corrosive place. Do not install the generator near to inflammables such oil paint, diluents and fuel. Be alert to the steam pipeline and safety valve since the high temperature of steam is dangerous to customers.
- Generator must be level installed.
- The generator should be installed in a dry and well-ventilated place. It can be installed either on the wall or on the ground, but must be well fixed. Install the generator as close to steam room as possible, such as in the closet, under the washing basin or in the basement. (Refer to figure 4).
 - i. Install the generator on the wall: drill two small holes with diameter of 8mm on the wall, insert the expansion screws and then hang the generator on those screws.
 - ii. Install the generator on the ground or deck: Install the frame on the site and then screw the generator into the frame.
 - iii. For better service and maintenance, please install the generator with the nameplate face to front

and leave more than 250mm space around the generator.

3. Installation of controller and temperature sensor

The controller should be installed with height of 1.2 m outside the steam room but nearby or other place where easy to operate. Firstly drill a hole with diameter of 50 mm on the installation site.

- Pull the control wire and temperature sensor wire through the conduit, then connect the control wire to the black connector(6-Pin) while connect the temperature sensor wire to the black connector(2-Pin). Finally the controller panel can be glued to wall by the attached double sided adhesive or apply silicon glue at the back of panel if needed (Refer to figure 5).
- The temperature sensor is used to measure the temperature inside the steam room, so that the generator can work automatically according to the pre-set temperature and maintain the room temperature constant. The installation height of the sensor should be about 1.2 –1.5 m from ground. Please drill a hole (diameter 16mm), and then nail down the sensor in the steam room (Refer to figure 6), pull the sensor wire through the conduit then connect to the black connector(2-Pin) of the controller.
- **Caution:** The control wire and temperature wire should not be parallel to or intersect with the power wire. The temperature sensor should not be installed on the side of the wall which is behind the door when the door is opened and the controller should not be installed in any moist place.

WARNING

Do not install sensor in adjacency to door or ventilation opening.

Figure 4

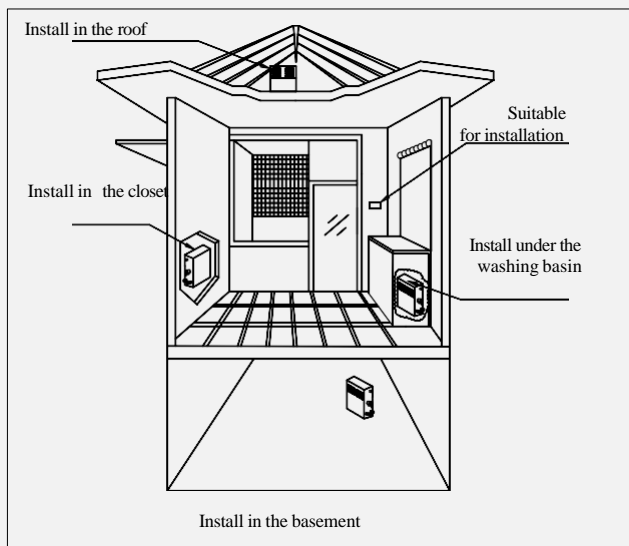

Figure 5

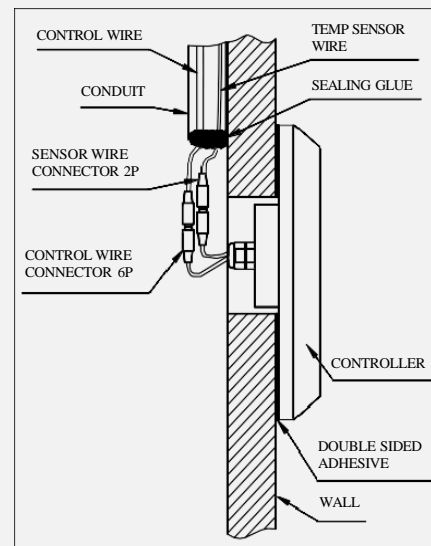
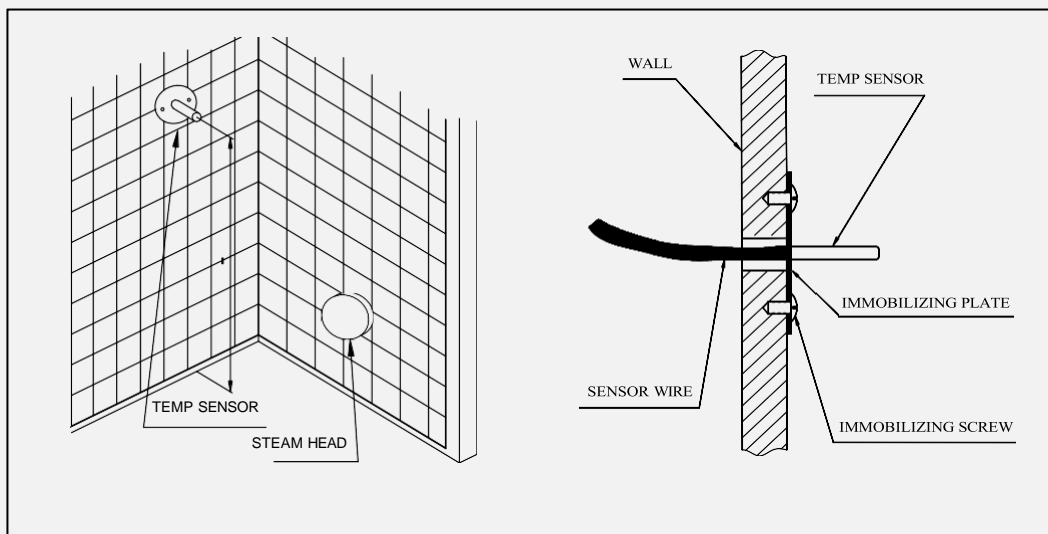

Figure 6



4. Installation of pipeline.

Caution:

- If the generator is installed at a place where difficult for customer access, the water inlet valve must be easy to access for emergencies.
- The solenoid valve can endure 0.06-0.55MPa (0.6-5.5kg/cm²) water pressure. To protect the solenoid valve from extremely high water pressure, please turn down the inlet slightly or install water pressure reducer valve.
- Do not install saddle-backed or needle valves on the inlet. Please dredge and clean the pipe before installation.
- No block valve should be installed in the steam pipelines. Strictly no blocked or blended pipe, otherwise have negative effect on the flow of steam and condensate. The steam pipelines should be installed with a slight angle so that the condensate can flow back to the generator or the steam head.
- Steam generator should be installed outdoors to prevent icing. The generator should be installed and leveled with the arrow pointing upward at an easy-access place, otherwise do not switch on.
- The steam pipeline must be copper pipes, all other material such as plastic, acrylic should not be used since they cannot endure 150°C or higher temperature.
- All inlet and apertures should be sealed to prevent any leakage of steam and protect the generator and customers.
- Draining water to the steam room from the water tank may cause serious scald and damage the steam room. A separate draining pipe is required to drain water to the drainage.

All inlet water pipes and steam pipelines should be built according to the National Standard (refer to Figure 7) and this should be done before sealing the wall.

Water inlet: First connect the water magnetizer (if applicable) to the water inlet solenoid valve.

Then please use a 1/2" flexible stainless steel hose to connect the other side of the water magnetizer and the water supply pipeline. Do not connect to metal water supply pipeline directly which may damage the water inlet valve. Only use cold water supply.

Steam outlet: Use no less than 1/2" copper pipe to connect the steam head and the steam outlet

pipe of the generator. The pipe should be less than 3 meters long and minimize the number of elbows, otherwise heat isolating methods should be implemented.

Steam head: The steam head should be about 300mm from the ground and at least 150mm from customer seats. Please apply silicone glue on the steam pipe nipple and back of the steam head, and then screw the steam head on to the steam pipe nipple. Please refer to part A in figure 7, the Aromatherapy reservoir should face upwards.

Drain pipe: Please use 1/2" copper pipe to connect the drain outlet and the drain pipeline of the house. Similarly, use 1/2" copper pipe to connect the safety valve and the drain pipeline of the house. The drain pipeline should be installed with small angle so as to help residual water in the steam generator flow to the drain pipe.

Figure 7

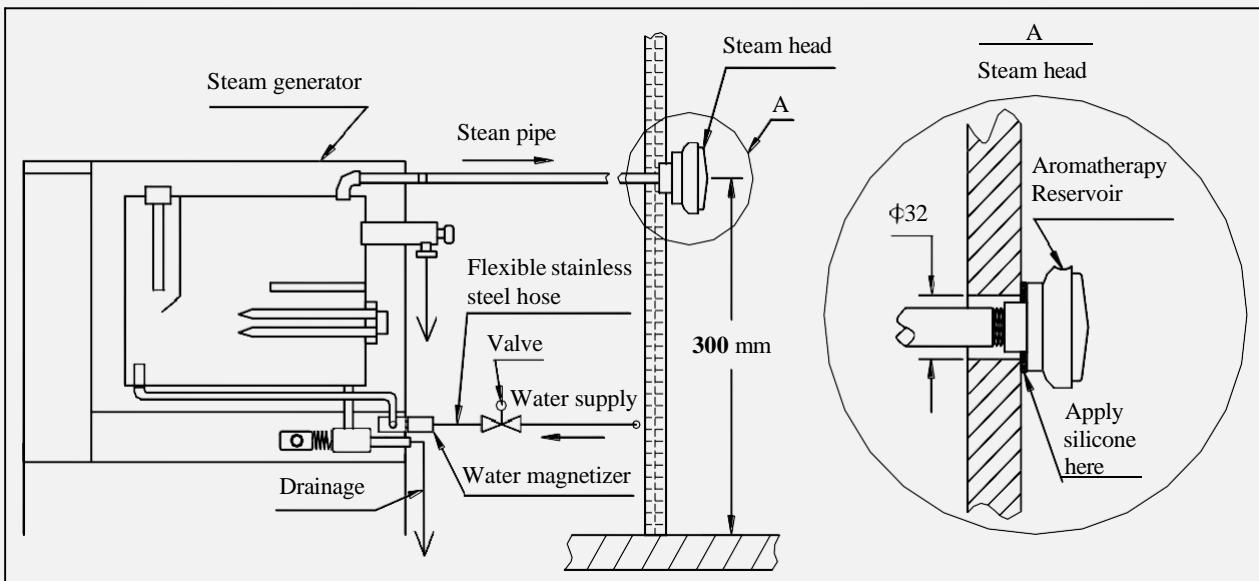

5. Electrical installation

Caution:

- All circuits should be installed by licensed electricians and conform to local and national codes.
- Power supply must be cut off before installation, maintenance and repair. Press the on/off button on the generator cannot cut power from the supply.
- No additional power supply or wire is allowed to connect to the generator. Do not connect the ground wire to the neutral wire.
- Only the original parts and elements from our factory are allowed to be used in installation, operation, maintenance and repair.
- After the installation of the pipeline and electrical circuits, careful checking must be performed before switch on the generator.
- The generator has been carefully installed, checked and tested in factory, thus customer only need to install the power wire and control wire.

INSTALLATION OF CONTROL WIRE

Take off the back cover of the generator, pull the control wire at the back of the controller through a conduit and then insert it into the hole at the back of the generator case and connect to the plug. (Refer to figure 8).

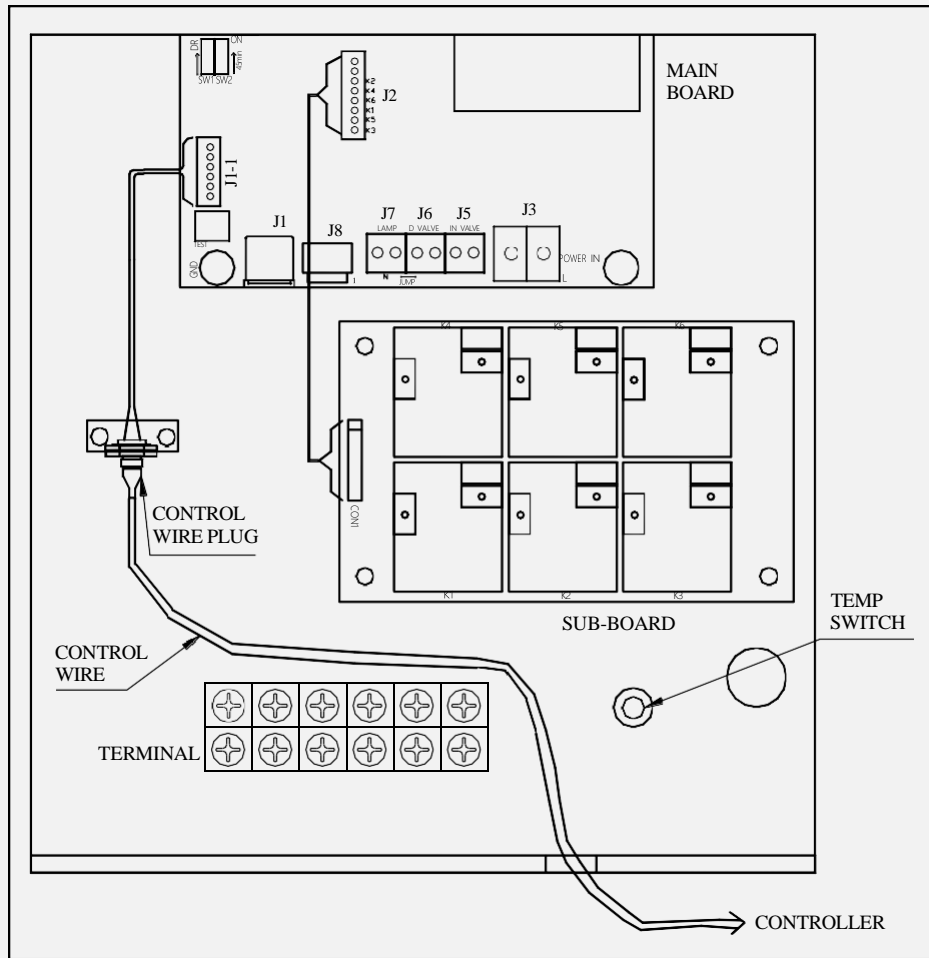

Figure 8

INSTALLATION OF POWER WIRE

Caution:

- The power supply should be 220-240V or 380-415V, 50/60Hz, please refer to the nameplate of the generator or table 1 of this manual.
- The selection of fuse and breaker must strictly follow the data in table 1.
- Choose the suitable power wire according to table 1 and local codes.

Take off the back cover of the generator, insert the 3-core power wire (single phase, 220-240V , 50/60Hz) or 5-core power wire (three phases 380-415V , 50/60Hz) into the hole at the back of the generator case and connect to the correct terminal. (Refer to figure9-12).

Single phase, 220-240V , 50/60Hz power supply: connect the live wire to the terminal labeled as “L” ; connect the neutral wire to the terminal labeled as “N” ; and connect the ground

wire to the terminal labeled as “ \perp ”.

Three phases, 380-415V , 50/60Hz power supply : connect the L1, L2, L3 wire to the terminal labeled as “L1”, “L2” and “L3” respectively; connect the neutral wire to the terminal labeled as “N”; and connect the ground wire to the terminal labeled as “ \perp ”.

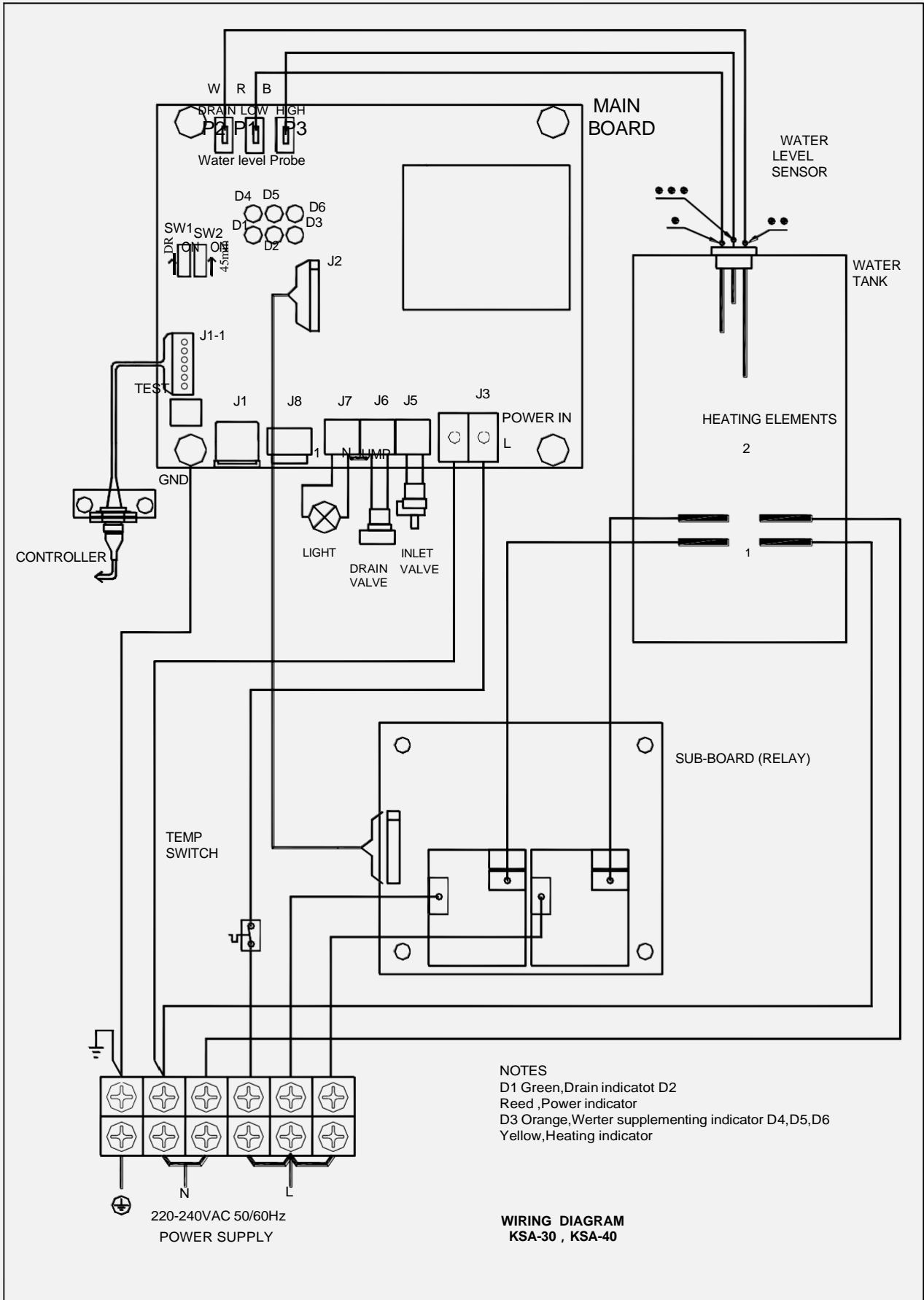

Figure 9

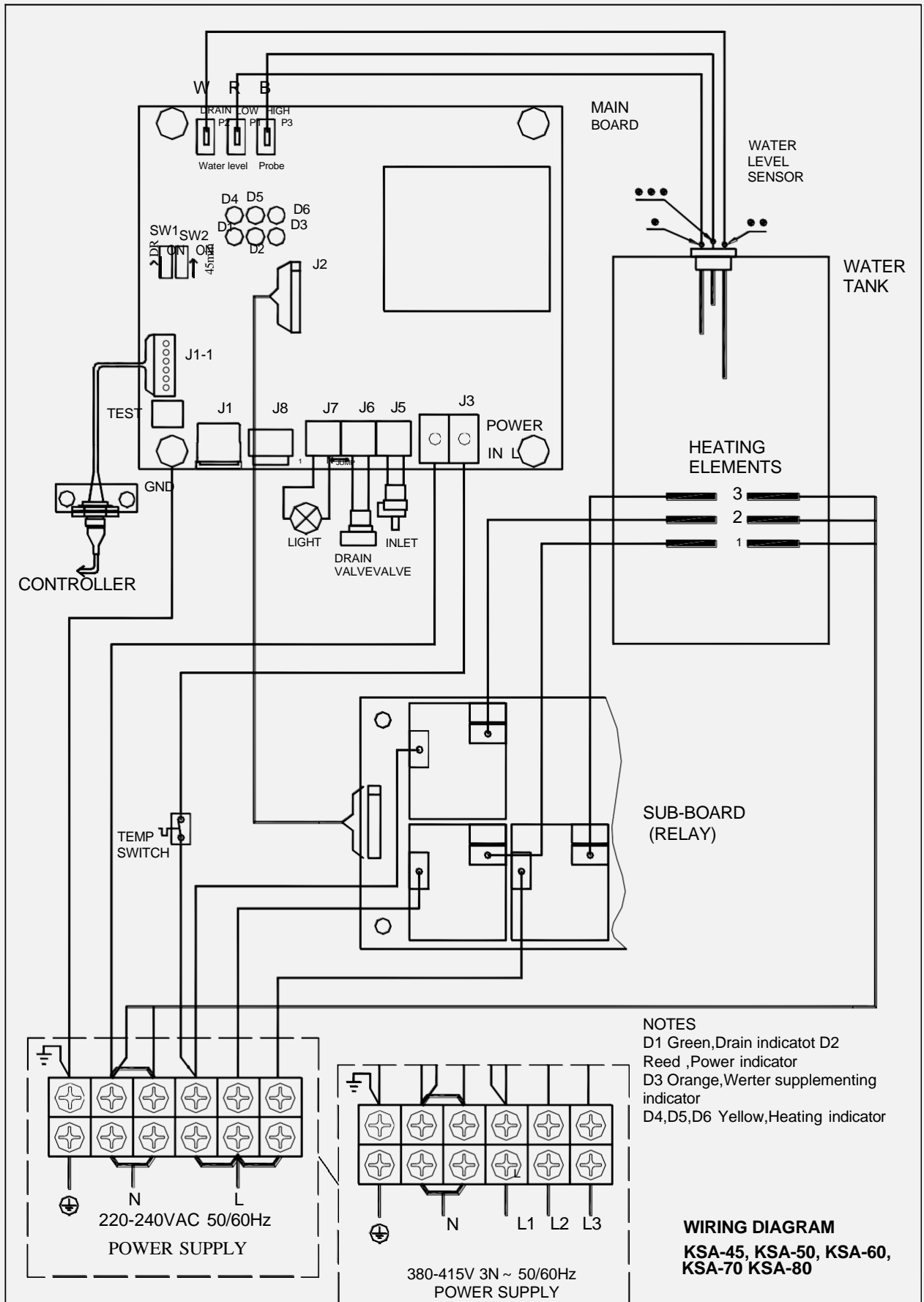

Figure 10

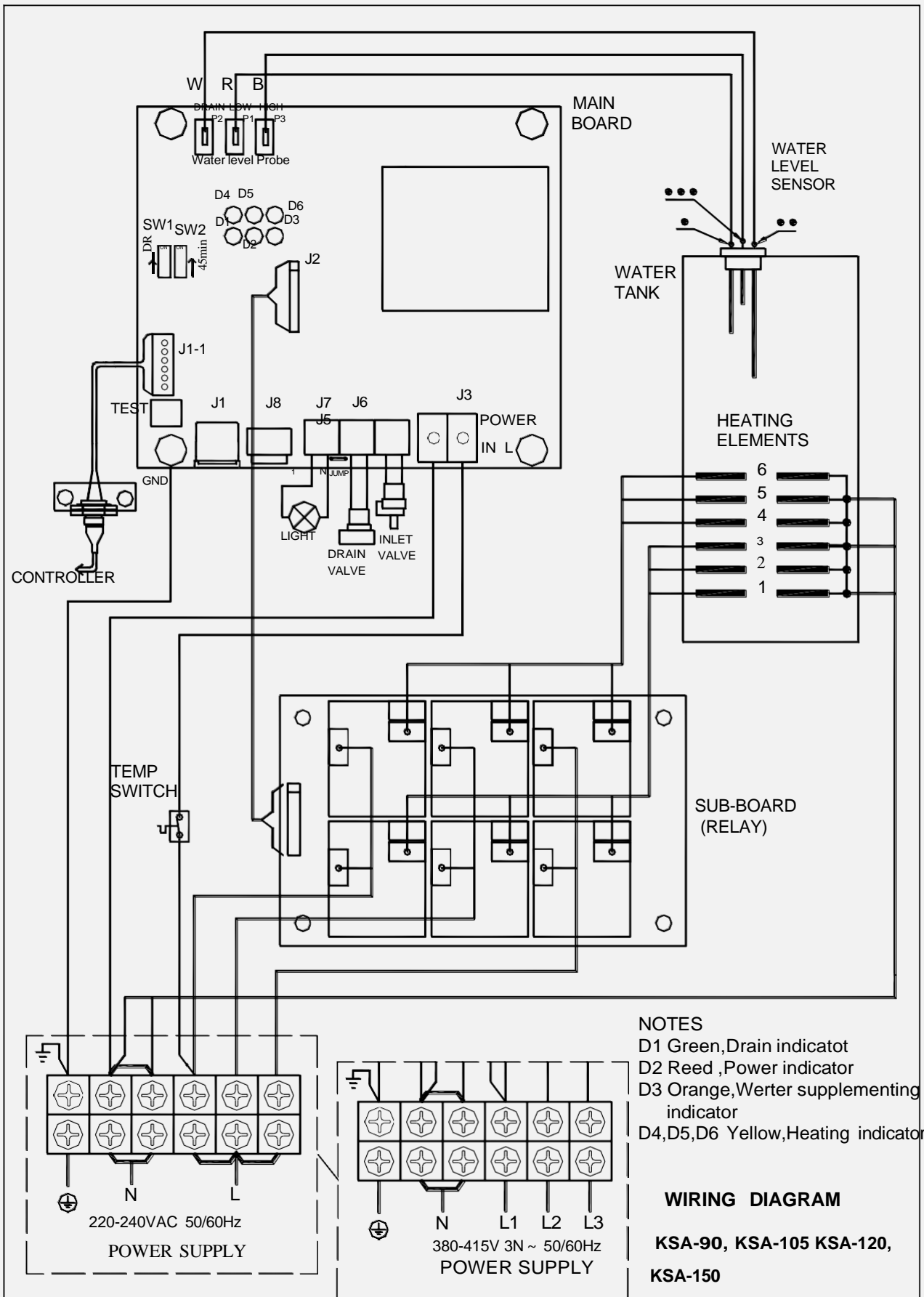

Figure 11

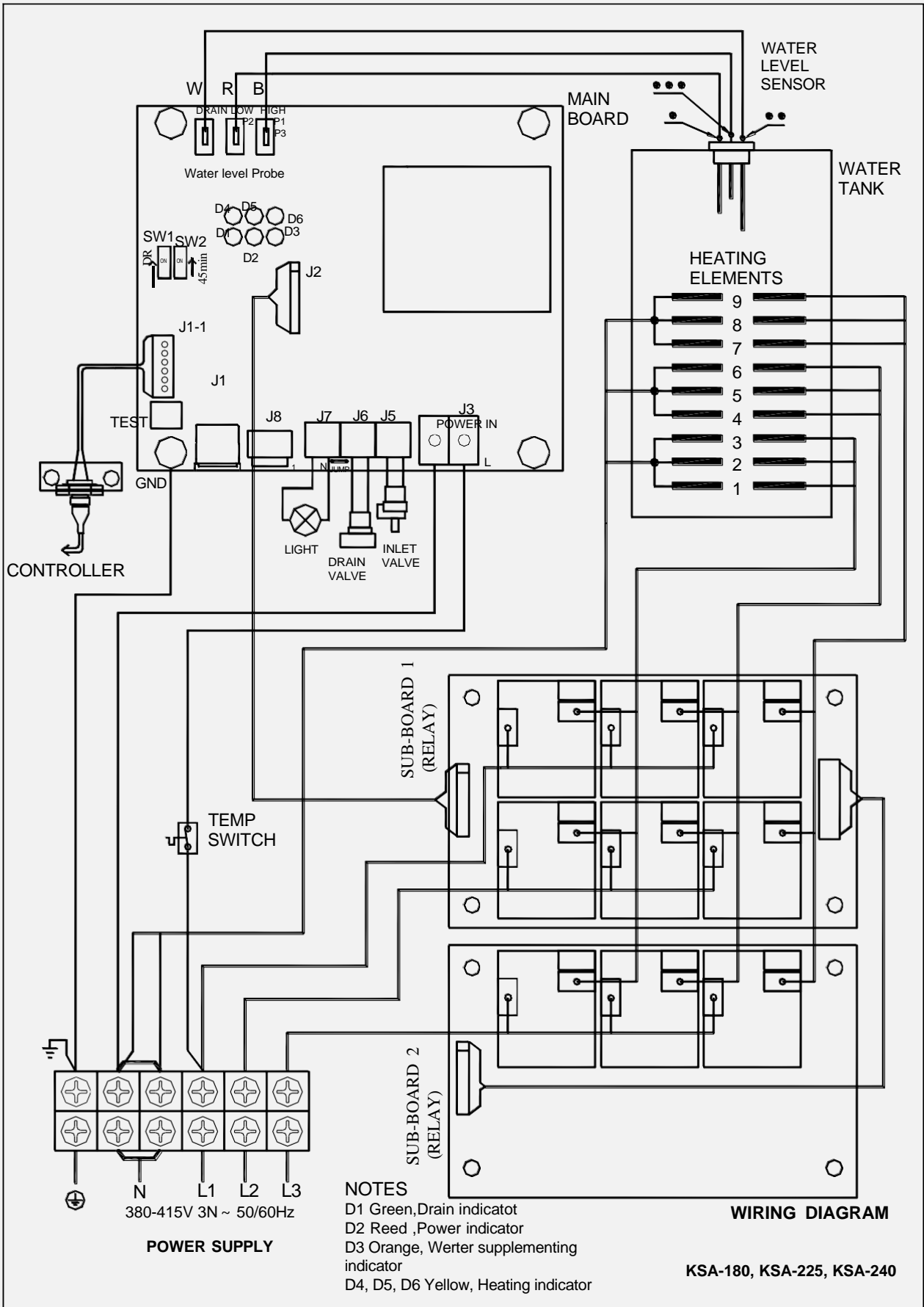

Figure 12

1. DISPLAY PANNEL

Temperature: The LCD will display the temperature measured by the temperature sensor in the range of 6°C ~ 60°C(43°F ~ 140°F).

Set temperature: The temperature setting range is 35°C ~ 55°C(95°F ~ 131°F) and indicated by the 5 red LEDs besides the LCD. The bottom LED is on when temperature is 35°C(95°F); the bottom two LEDs are on when the temperature is within range of 36°C ~ 40°C(97°F ~ 104°F); three LEDs are on when temperature is within range of 41°C ~ 45°C(106°F ~ 113°F); four LEDs are on when temperature is within range of 46°C ~ 50°C(115°F ~ 122°F); all LEDs are on when temperature is within range of 51°C ~ 55°C(124°F ~ 131°F). The default setting temperature is 43°C(109°F).

Set time: The maximum setting time is 60 minutes and the remaining time is indicated by the 5 red LEDs besides the LCD. The bottom LED is on when the remaining working time is 20 minutes or below; the bottom two LEDs are on when the remaining working time is within range of 20~30minutes; three LEDs are on when the remaining working time is within range of 30~40minutes; four LEDs are on when the remaining working time is within range of 40 ~ 50 minutes; all LEDs are on when the remaining working time is within range of 50~60 minutes. The default working time is 45 minutes. If the system is in long-term working mode, the top LED blinks.

Hint message:

- 1) **Temperature is lower than 6°C (43°F):** LCD displays “-L”, detected by the temperature sensor.
- 2) **Temperature is higher than 60°C (140°F):** LCD displays “-H”, detected by the temperature sensor, all heating elements stop working.
- 3) **Water supply fault:** LCD displays “- E”. This message appears when the water level is lower than the minimum water level 10 minutes after the system is started and the water inlet valve is opened, or the water level is lower than the desired level 3 minute after the water supplementing order is given. It indicates faults of the water supply system, all heating elements stop working.
- 4) **Drainage:** LCD displays “-d”, indicating automatic draining after the pre-set job is done (**ON/OFF** button is pressed or setting time is up), then the whole system will shut down automatically.
- 5) **Connection error:** LCD displays “EE” showing any connection error between the controller and the main PCB.
- 6) **Heating up:** indicated by the three-color LED on the left of the panel with label “”.
 - a) If has two groups of heating elements (1~6 elements): if the indicator is red or green, then the actual temperature is below the setting value and both two groups of heating elements are working; if the indicator is blue, then the actual temperature is 2°C(4°F) higher than the setting value so only one group of heating elements is working.
 - b) If has three groups of heating elements (9 elements): if the indicator is red, then the actual temperature is below the setting value more than 2°C(4°F) and all three groups of heating elements are working; if the indicator is green, then the actual temperature is less than 2°C(4°F) lower than the setting value so two groups of heating elements are working; if the indicator is blue, then the actual temperature is 2°C(4°F) higher than the setting value, so only one group of elements is working.

- 7) **Insulation:** indicated by the LED on the right of the panel with label “”. If the current temperature is more than 2°C(4°F) above the setting temperature, all heating elements stop working and the system is under insulation function.

2. FUNCTION BUTTONS AND OPERATION

ON/OFF: to switch on and off of the whole system. Press this button can switch on the

generator and open the water inlet solenoid valve to fill in water. When the water level reaches the required minimum water level, system begins to heat up (if current temperature is lower than setting temperature). Once the water level reaches its maximum level, inlet valve closes and the system enter the automatic working process. If the system was shut off by pressing **ON/OFF** button previously, system will adapt the default temperature and time setting; otherwise if the system is shut off automatically when setting time is up, system will adapt the previous temperature and time setting. Then system begins to heat up and produce steam after several minutes. Press the **ON/OFF** button again will shut down the system manually and the system will drain automatically.

SET: Temperature and Time setting button. Press once to adjust the temperature. The LCD and the

red LED on the left will blink and display the previous setting temperature. If the system has been turned off and restarted, the LCD displays the default temperature 43°C(109°F), then press the “▲” or “▼” button to adjust and press “**SET**” again to confirm your setting.

At this time, the LCD and LEDs on the right blink and display the previous setting time or the default setting time 45 minutes if the system has been turned off and restarted, or the remaining working time(during working time), you could set the working time now. Press

“▲” or “▼” button to adjust the working time to the value you want, or press “▲”

button until the LCD displays “**CH**” and then press “**SET**” to confirm, after that the

system automatically enters long-term working mode. The available temperature range is 35°C ~

55°C(95°F ~ 131°F) , and the default temperature is 43°C(109°F),When the system is in long-term

mode, five red LEDs on the right side of the LCD are on and the top one blinks.

When the working time is set, the maximum working time is 60 minutes and the default working time is 45 minutes.

PAUSE: Press this button to pause the system. The heating indicator is off, the insulation indicator blinks, and all function buttons are not function except “**ON/OFF**” button and “**LIGHT**” button. If is not in long-term mode, system will automatically drain and switch off once the working time is over. Press this button again to stop.

LIGHT: Switch for the external light. The button can be used as the switch for the external light as long as the system is connected to power supply. The LED is on when the light is turned on.

▲ Increase the temperature or time.

▼ Decrease the temperature or time.

3. AUTO FUNCTIONS

Auto filling: inlet valve will open automatically once the system is started and fill in water

automatically until the water level reaches maximum level. If water level is still lower than the minimum water level 10 minutes after, it indicates faults of the water supply system, so all heating elements will stop working and LCD will display “-E”.

Auto heating up by sections: generator will compare the measured room temperature with the setting temperature and then decides the number of working heating elements.

Auto water supplementing: if the water level is lower than the desired level when operating, auto water supplementing function will be on and open the inlet valve. Once the water level reaches the desired level, auto water supplementing function turns off. If water level is lower than the desired level 3 minute after the water supplementing order is given, it indicates faults of the water supply system, so all heating elements stop working and LCD displays “-E”.

Auto drainage: when setting time is over or **ON/OFF** button is pressed, system will drain automatically and displays ‘-d’ on the LCD. The drainage valve will be turned on to drain. After a while the system will open the inlet valve to fill in water in order to wash and cool down the inner tank and heating elements. The whole process is about a few minutes, and the system will be shut off automatically after drainage.

CHAPTER 4 MAINTENANCE

1. As leakage of the steam will damage the equipment. To prevent any hazard, steam generators, steam head, parts and pipe line connections should be checked regularly.
2. Clean the solenoid valve, magnetizer and all the other sets in the pipe line regularly according to the local water quality and usage of the steam generator.
3. When operate, check the equipment to see whether it's over heated, check the stability and corrosion of all the wire plugs.
4. **Replace the heating elements:** Switch off the steam generator and remove the element access cover when the generator completely cools down. Label the wires connect to the heating elements which need to be replaced and plug out the wires. Screw the heating elements out. Clear the scale in the water tank and screw in the heating elements after putting the rubber rings on them (airproof gasket should be pressed firmly without reversion). Plug on the wires, make sure the heating elements are properly connected before put on the element access cover.
5. **Replace the main board:** Switch off the steam generator and remove the U shape cover when the generator completely cools down. Label the three wires which connect the upper part of the main board to the water level sensor and the source, drain valve and water inlet solenoid valve in the bottom part of the main board. Unplug these wires and remove the main board (be careful with yellow-green ground wire under the screws of the circuit board). Install the main board back carefully.
6. **Replace the sub-board:** Switch off the steam generator and remove the U shape cover when the generator completely cools down. Unplug all the wires on the sub-board. Label all the wires on the relay and remove the sub-board. Install the sub-board back carefully.

7. Replace the solenoid valve, drain valve and Auto drain motor (drain pump): Switch off the steam generator and disconnect from the power and water supply. Remove the water inlet, steam outlet and draining pipelines after the generator completely cools down. Then please lean the steam generator to remove the base panel. After that, please take off the soft pipes, wires and screws so that the faulty valve could be removed. Finally please install the replacing valve carefully.

8. Replace the water level sensor: Switch off the steam generator and remove the small cover on the equipment when the generator cools down. Special care should be taken to the plugs of the water level sensor corresponding to the blue wire, the red wire and the white wire respectively. Take off all the wires, screw out the water level sensor, and screw in the new water level sensor until the bottom of the plastic nut reaches the same height as the old one. Finally reconnect the wires (all wire must be plugged back to the right place. Refer to figure 9-12).

- **Cut off the power supply before any maintenance.**
- **Test the equipment after maintenance.**

CHAPTER 5

TROUBLESHOOTING

Repair can only be performed by qualified professionals, for more services or technical helps please contact the dealer.

KSA model steam generator has self-diagnose function, and some common faults will be displayed on the LCD if occur.

Code	Meaning	Diagnose and Solution
-L	Temperature measured by temperature sensor is below 6°C	Check whether the room temperature is below 6 °C, the code should disappear after the room temperature reaches 6 °C. Otherwise check the connection of the sensor.
-H	Temperature measured by temperature sensor is higher than 60°C	Check whether the room temperature is above 60 °C, the code should disappear after the room temperature drops below 60 °C. Otherwise check the connection of the sensor.
-E	Fault on the water supply, heating elements stop working	Check the connection and status of solenoid valve, water supply , magnetizer and water level sensor. After clean or replacement, restart the system and you should feel the flow of incoming water.
EE	Connection error between control panel and main board.	Check the connection wire and connectors between the control panel and the main board.
d	Automatically draining when setting time is up or ON/OFF button is pressed. Automatically shut down after draining for a few minutes	Normal

Table 3

Diagnosing procedure:

1. Take off the U shape cover at the back of the generator and plug out the connection wire for controller, then press the "TEST" button. If the generator can fill in water -> heat up -> produce steam, and stop working when press the "TEST" button again, it means that the main circuit board is working properly and the faults should be on controller part (including temperature sensor), then please replace the faulty parts. Otherwise the faults are on the main board, sub-board, water level sensor, inlet solenoid valve or inlet pipelines, please carefully test each part and replace the faulty ones.
2. If the generator can fill in and drain out water properly but does not heat up, please check the connection wire between main circuit board and the sub-board, the relays on sub-board, and heating elements.
3. If water comes out from the steam outlet pipe seriously, please clean or change the outlet solenoid valve.
4. If the system keeps on heating up even if the current temperature is more than 2°C above the setting value with the indicator on, carefully test the relays on the sub-board and change the faulty ones, or change the whole sub-board.
5. All troubleshooting process could refer the indicators on the main board.

D1	D2	D3	D4, D5, D6	
GREEN	RED	ORANGE	YELLOW	
DRAINAGE	POWER	WATER FILLING IN	HEATING UP	

- Please refer to the circuit and connection diagrams for diagnosing and repair.
- Do cut off the power supply before repair.
If problems still cannot be solved by the procedures listed above, please contact the dealer.

CHAPTER 6

WARRANTY AND SERVICES

Limited warranty is offered to all customers. Any quality problem will be covered for one year (from the purchasing date) or 18 months (from the factory producing date) under free warranty (base on the earlier one). Damaged accessories, parts, and knobs are not under warranty.

- Heating elements are under 90 days (from installation) or half year from the factory producing date) free warranty (base on the earlier one).
- Our company has the right to decide whether to repair or to change. Approval must be obtained from our company before shipping back the product. The customer has to pay for the transportation fee and any parts fee beforehand.
- Any clause mentioned in the manual is not covered by the warranty.

- This warranty does not cover any defect, malfunction or failure caused by, or resulting from unauthorized installation, maintenance and repair; improper power supply; and any action which violates the manual.
- Damage caused by accident, misusing of chemistry products, or any other reason which are beyond our company's responsibilities will not be covered. Any product whose label, nameplate has been removed, altered, damaged is not covered either.
- Using in a salty environment or any other extreme, corrosive condition is not covered by the warranty.
- After the free warranty period, services are still available if all cost is covered by the customer.
- Our company is not responsible for any direct or indirect damage caused by the generator.
- Please contact our company for further information and more details.

APPENDIX: PARAMETER OF SPECIAL MODELS

Model	Power kW	Voltage V/current A	Power line size N*mm ²	Fuse or breaker A
KSA-90	9.0	220-240/41	3*10.0	60
KSA-105	10.5	220-240/48	3*10.0	60
KSA-120	12.0	220-240/55	3*10.0	100

Notice: We do not recommend customer to choose special models. However we could still specialize our system for customers if they have special needs due to restrain of space or power supply. Wiring diagram refer to figure 11.

